

PROHIBITED LOCATIONS AT INTERSECTIONS FOR RURAL VEHICLE CROSSINGS

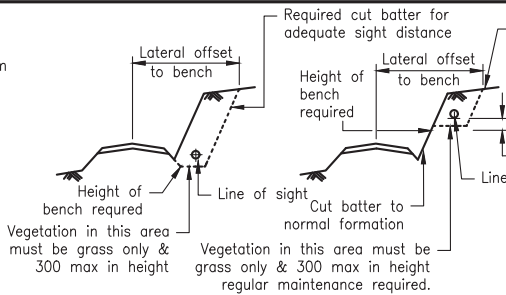

BENCHING DETAIL SECTION B-B

Catchment Area	PIPE SIZE	
	ARI 2	ARI 10
<0.5Ha	375	450
<1.0Ha	450	525
<1.5Ha	525	600
<2.5Ha	600	2/450
<3.0Ha	2/450	2/525
<4.0Ha	2/525	2/600
<5.0Ha	2/600	(2)

For average daily traffic \leq 2000, ARI 2
 For average daily traffic $>$ 2000, ARI 10

(1) Alternatives may be approved if supported with calculations in accordance with the provisions of the Queensland Urban Drainage Manual or under the provisions of Council's Planning Scheme.

(2) Seek consulting engineer advice.

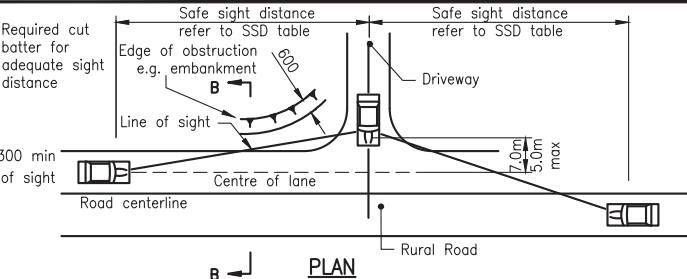

PLAN

Speed Limit (km/h)	Safe Sight Distance (m)
40	73
50	97
60	123
70	151
80	181
90	214
100	248

Based on Austroads Part 4A - 2009, Table 3.2

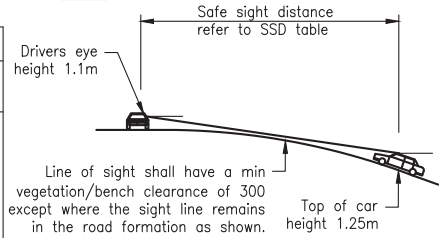

LONGITUDINAL SECTION SSD - EXITING FROM DRIVEWAY

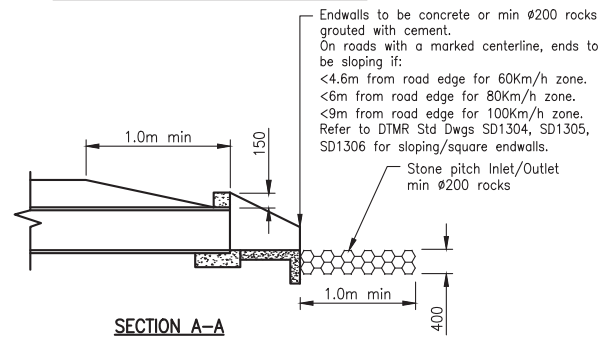

SECTION A-A

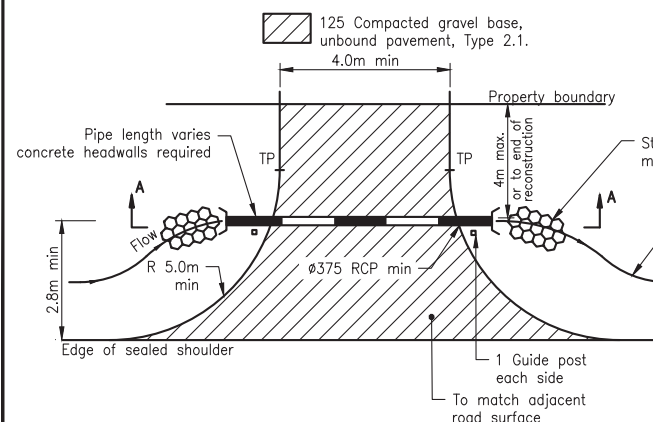

VEHICLE CROSSING PLAN

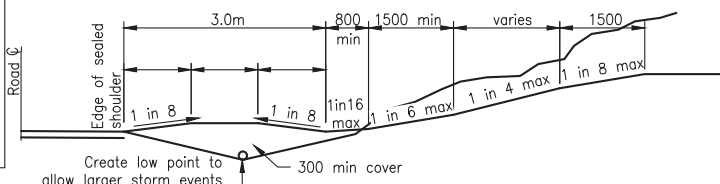

TYPICAL DRIVEWAY SECTION - ROAD IN CUT

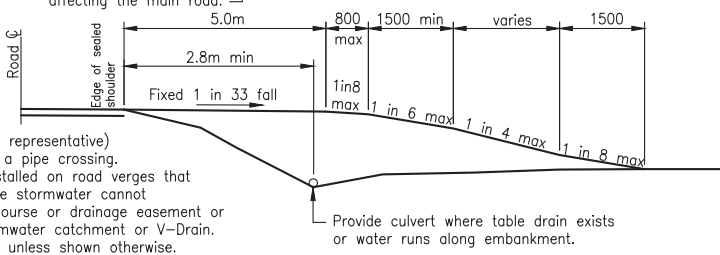

TYPICAL DRIVEWAY SECTION - ROAD IN FILL

NOTES:

- A site assessment (By a Council representative) is to occur upon application for a pipe crossing. Pipe crossings are not to be installed on road verges that fall to the subject property where stormwater cannot be directed to a natural water course or drainage easement or when there is no upstream stormwater catchment or V-Drain.
- All dimensions are in millimetres unless shown otherwise.

These drawings have been developed in consultation between the participating Councils. BEFORE USE, the user shall confirm that the drawing has been adopted by the appropriate Council.

REV.	DATE	REVISIONS
F	06/14	Review
E	03/14	Amended Drawing Number
D	12/11	Drawing number changed from SEQ R-056 to RS-056
C	06/10	Review
B	06/09	Review
G	06/16	Review
Rv.		DATE



**INSTITUTE OF PUBLIC WORKS ENGINEERING AUSTRALASIA
 STANDARD DRAWINGS**

**VEHICLE CROSSINGS
 RURAL DRIVEWAY**

RS-056

P
R
I
N
T
I
N
G